Service Bulletin

June 16, 1995

MEB95-9

TITLE

CABIN HEATER FUEL LINE INSPECTION/REPLACEMENT

EFFECTIVITY

<u>Model Series</u>	<u>Year</u>	<u>Serial Numbers</u>		
310	1955 thru 1960	35000	thru	39264
310		607		
310E	1960	310M0001	thru	310M0036
310E		35912A		
310F	1961	310-0001	thru	310-0156
310G	1962	310G0001	thru	310G0156
310H	1963	310H0001	thru	310H0148
310I	1964	310I0001	thru	310I0200
310J	1965	310J0001	thru	310J0200
310K	1966	310K0001	thru	310K0245
310L	1967	310L0001	thru	310L0207
310N	1968	310N0001	thru	310N0198
310P	1969	310P0001	thru	310P0240
310Q	1970 thru 1974	310Q0001	thru	310Q1160
310R	1975 thru 1981	310R0001	thru	310R2140
320	1962	320-0001	thru	320-0110
320A	1963	320A0001	thru	320A0047
320B	1964	320B0001	thru	320B0062
320C	1965	320C0001	thru	320C0073
320D	1966	320D0001	thru	320D0130
320D		623		
320E	1967	320E0001	thru	320E0110
320F	1968	320F0001	thru	320F0045
320F		658		
340	1972 thru 1975	340-0001	thru	340-0555
340A	1976 thru 1984	340A0001	thru	340A1817
411	1965 thru 1966	411-0001	thru	411-0250
411A	1967 thru 1968	411-0251	thru	411-0300

To obtain satisfactory results, procedures specified in this publication must be accomplished in accordance with accepted methods and prevailing government regulations. The Cessna Aircraft Company cannot be responsible for the quality of work performed in accomplishing the requirements of this publication.

PURPOSE

The cabin heater fuel line should be inspected for fuel leaks and corrosion. Leaking fuel lines should be repaired or replaced based on results of the inspection. Minor corrosion pitting can be repaired but line replacement is required if pitting exceeds the limit allowed by this service bulletin. Non-compliance with this service bulletin could result in failure of the cabin heater fuel line; which could subsequently result in a fire.

COMPLIANCE

Mandatory, shall be accomplished within the next 100 hours of operation or 12 months, whichever occurs first.

APPROVAL

FAA approval has been obtained on technical data in this publication that affects airplane type design.

MAN-HOURS

Not determined.

MATERIAL

The following parts are available from Cessna Parts Distribution thru an appropriate Cessna Service Station for the suggested list price shown.

<u>Part Number</u>	<u>Description</u>	<u>Qty./Airplane</u>	<u>Price</u>
S617780 (See Note 1)	Tube, 321 Stainless Steel	1	\$ 15.80 (PS) ea.
S617847 (See Note 2)	Tube, 321 Stainless Steel	1	\$ 7.24 (PS) ea.
AN818-4K	Nut	2	\$ 3.50 (PS) ea.
MS20819-4K	Sleeve	2	\$ 1.90 (PS) ea.
CMNP021CLASSB1/2 (Alternate MILS8802IIB1/2)	Sealant (2.5 Oz. SemKit)	1	\$ 24.50 (X) ea.

NOTE 1: Applicable to model 310, 320, and 340 airplanes.

NOTE 2: Applicable to model 411 airplanes.

ALL PRICES SUBJECT TO CHANGE WITHOUT NOTICE

ACCOMPLISHMENT INSTRUCTIONS

Cabin Heater Fuel Supply Line Inspection/Replacement Accomplishment Instructions are attached.

CREDIT

Not applicable.

OWNER NOTIFICATION

On June 16, 1995, the following Owner Advisory message will be sent to applicable owners of record in MEB95-9A.

Dear Cessna Owner,

The cabin heater fuel line should be inspected for fuel leaks and corrosion. Leaking fuel lines should be repaired or replaced based on results of the inspection. Minor corrosion pitting can be repaired but line replacement is required if pitting exceeds the limit allowed by this service bulletin. Non-compliance with this service bulletin could result in failure of the cabin heater fuel line; which could subsequently result in a fire.

Compliance is mandatory; shall be accomplished within the next 100 hours of operation or 12 months, whichever occurs first.

Please contact your Cessna Multi-Engine Service Station and arrange to have the heater fuel line on your airplane inspected.

* * * * *

TITLE CABIN HEATER FUEL SUPPLY LINE INSPECTION/REPLACEMENT

EFFECTIVITY

MODEL(S)	SERIAL NUMBERS
310	607, 35000 Thru 39264
310E	35912A, 310M0001 Thru 310M0036
310F	310-0001 Thru 310-0156
310G	310G0001 Thru 310G0156
310H	310H0001 Thru 310H0148
310I	310I0001 Thru 310I0200
310J	310J0001 Thru 310J0200
310K	310K0001 Thru 310K0245
310L	310L0001 Thru 310L0207
310N	310N0001 Thru 310N0198
310P	310P0001 Thru 310P0240
310Q	310Q0001 Thru 310Q1160
310R	310R0001 Thru 310R2140
320	320-0001 Thru 320-0110
320A	320A0001 Thru 320A0047
320B	320B0001 Thru 320B0062
320C	320C0001 Thru 320C0073
320D	623, 320D0001 Thru 320D0130
320E	320E0001 Thru 320E0110
320F	658, 320F0001 Thru 320F0045
340	340-0001 Thru 340-0555
340A	340A0001 Thru 340A1817
411	411-0001 Thru 411-0250
411A	411-0251 Thru 411-0300

DESCRIPTION

Inspect for corrosion and/or leaks in cabin heater fuel supply line.

APPROVAL

FAA approval has been obtained on technical data in this publication that affects airplane type design.

REFERENCE

MEB95-9

June 16, 1995

Page 1 of 7

To obtain satisfactory results, procedures specified in this publication must be accomplished in accordance with accepted methods and prevailing government regulations. The Cessna Aircraft Company cannot be responsible for the quality of work performed in accomplishing the requirements of this publication.

The Cessna Aircraft Company, Product Support, P.O. Box 7706, Wichita, Kansas 67277, U.S.A. (316) 941-7550, Facsimile (316) 942-9006

COPYRIGHT © 1995

ACCOMPLISHMENT INSTRUCTIONS

MEB95-9

CHANGE IN WEIGHT AND BALANCE

None

MATERIAL INFORMATION

All models except Model 411 airplanes, order the following parts:

PART NUMBER	QUANTITY	DESCRIPTION
S617780	1	Tube, 321 Stainless Steel
AN818-4K	2	Nut
MS20819-4K	2	Sleeve

For Model 411 airplanes, order the following parts:

PART NUMBER	QUANTITY	DESCRIPTION
S617847	1	Tube, 321 Stainless Steel
AN818-4K	2	Nut
MS20819-4K	2	Sleeve

In addition to the parts listed above, the following will be required to accomplish this service bulletin:

NAME	NUMBER	MANUFACTURER	USE
Cleaner	Metal Glo #6	Turco Products Division Purex Corporation Ltd. 24600 South Main St. Carson, CA 90745	Corrosion removal
Color Chemical Coating	Alodine 1200S	Amchem Products, Inc. Brookside Avenue Ambler, PA 19002	Prepare aluminum surface for corrosion resistance
Color Chemical Coating	Iridite 14-2	Richardson Chemical Co. Allied-Kelite Products Div. 400 Midland Avenue Highland Park, MI 48203	Prepare aluminum surface for corrosion resistance
Sealant, High Adhesion	CMNP021CLASS B1/2 Alternate is MIL S8802IIB1/2 or equivalent	Available from Cessna Parts Distribution	Corrosion protection on fitting threads

Equivalent substitutes may be used

ACCOMPLISHMENT INSTRUCTIONS

MEB95-9

ACCOMPLISHMENT INSTRUCTIONS

1. Disconnect all electrical power from the airplane. Attach maintenance warning tags to the battery connector(s) and external power receptacle stating:

WARNING: DO NOT CONNECT ELECTRICAL POWER — MAINTENANCE IN PROGRESS.

WARNING: OBSERVE ALL FUEL SYSTEM FIRE AND SAFETY PRACTICES

2. Ground the airplane from two (2) separate grounding positions to two (2) separate approved grounding points.
3. (Refer to Figure 1 and/or Figure 2.) Gain access to the cabin heater fuel supply line by removing the co-pilot seat, carpet, cockpit interior, access panels and/or nose baggage interior and insulation as needed. (Refer to the Service Manual.)

NOTE: The cabin heater fuel supply line in the cabin and nose baggage are the areas of concern in pressurized airplanes.

4. Inspect the fuel line for corrosion and/or leaks. (Refer to the Service Manual.)

CAUTION: USE PROTECTIVE CLOTHING, RUBBER GLOVES, AND EYE PROTECTION WHILE USING METAL GLO #6 FOR CORROSION REMOVAL.

5. Mix Metal Glo #6 with equal amounts of water per manufacturers instructions.
6. Remove light corrosion pits less than 0.005 inch deep or surface discoloration as follows:

- A. Apply diluted Metal Glo #6 with brush or cloth to affected area.
- B. Agitate with short fiber brush or abrasive mat until all corrosion is removed.

CAUTION: DO NOT LEAVE CLEANER IN CONTACT WITH THE SURFACE FOR MORE THAN FIVE (5) MINUTES.

- C. Rinse the area with a damp cloth, rinsing the cloth frequently in tap water.
 - D. Repeat cycle as required.
 - E. After all corrosion is removed, thoroughly rinse treated area with clean tap water.
 - F. Apply pretreatment (Iridite 14-2 or Alodine 1200S), per the manufacturers' instructions, to aluminum line where corrosion was removed.
7. Remove moderate corrosion pits greater than 0.006 inch deep but less than 0.016 inch deep as follows:
 - A. Apply the diluted Metal Glo #6 with a brush or cloth, wetting the entire corroded surface thoroughly.
 - B. Allow the solution to stand three (3) to five (5) minutes to remove corrosion, but not to exceed five (5) minutes.
 - C. Scrub with a short fiber brush just before rinsing with tap water or a damp cloth.
 - D. Repeat cycle as necessary.
 - E. After all corrosion is removed, thoroughly rinse treated area with clean tap water and dry.
 - F. Apply pretreatment (Iridite 14-2 or Alodine 1200S), per manufacturers instructions, to aluminum line where corrosion was removed.
 - G. If no leaks are detected, and if no connections were loosened, proceed to step 10.

ACCOMPLISHMENT INSTRUCTIONS

MEB95-9

8. If leaks are detected that are a result of material corrosion, or if corrosion in excess of 1/2 the wall thickness, (0.017 inch deep), is found, the line assembly shall be replaced. (Refer to the Service Manual, Heating System - Maintenance Practices.)

CAUTION: MINIMUM BEND RADIUS IS 0.560 INCH.

- A. Replace damaged or corroded line with a current new aluminum line assembly. (Refer to applicable parts catalog for part number of existing line assembly.), or using the S617780, or S617847 321 stainless steel tube (which ever is applicable), AN818-4K nuts, and MS20819-4K sleeves, fabricate a new line to match the existing cabin heater fuel supply line.

NOTE: Coat threads of existing fittings with CMNP021CLASSB1/2 sealant, or equivalent, to prevent dissimilar metal corrosion.

NOTE: To fabricate and install the new tube, it may be necessary to reform tube during the installation process.

9. Perform a leak check of the fuel line and fittings and an operational check of the cabin heater. (Refer to the Service Manual and Pilot's Operating Handbook.)

NOTE: If signs of water leakage are evident in cockpit, inspect windshield for water leaks and reseal as required. (Refer to applicable Service Manual.)

10. Reinstall all insulation and interior removed in step 2. (Refer to applicable sections of the Service Manual.)
11. Make an entry in the airplane logbook stating compliance with this service bulletin and method of compliance.

ACCOMPLISHMENT INSTRUCTIONS

MEB95-9

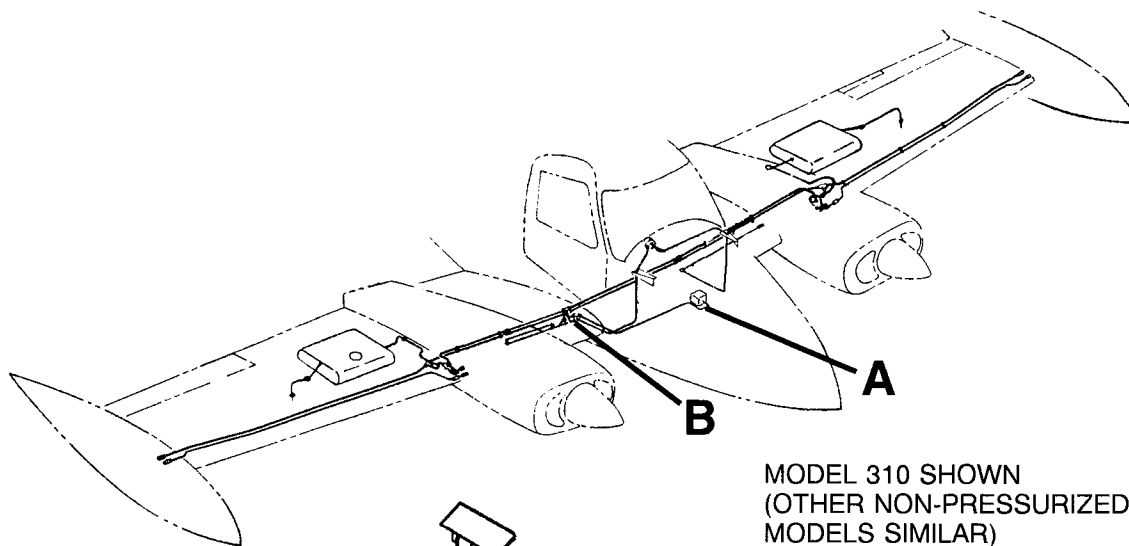

MODEL 310 SHOWN
(OTHER NON-PRESSURIZED
MODELS SIMILAR)

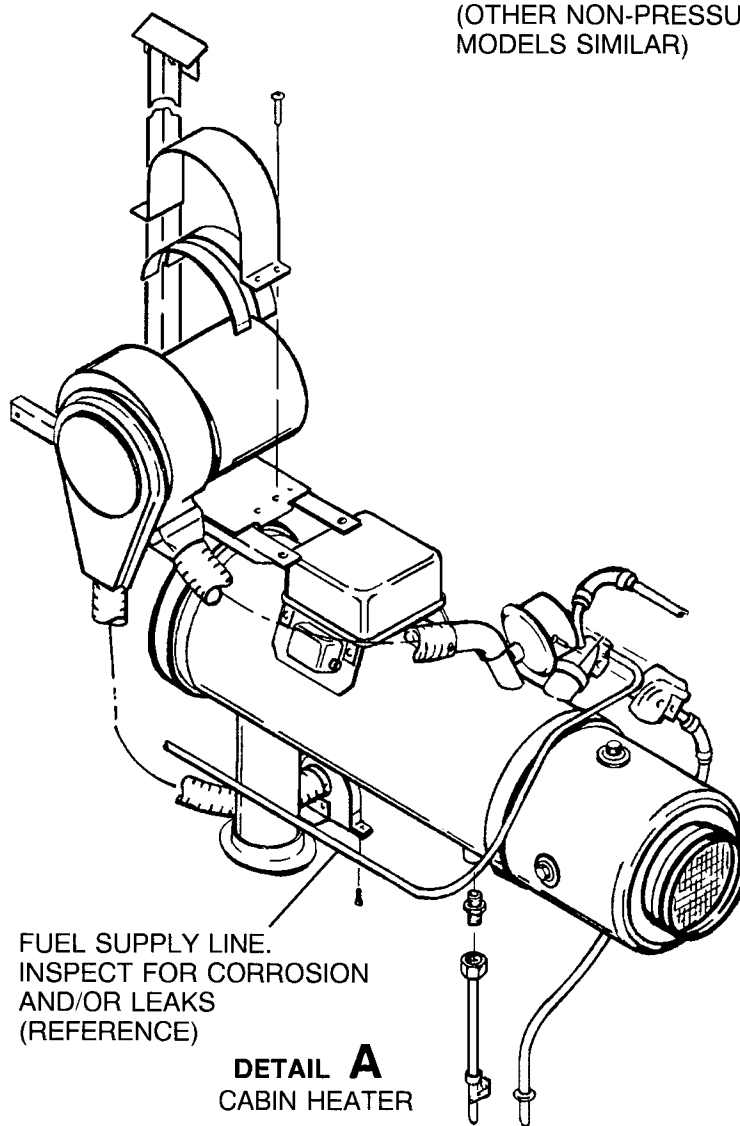

FUEL SUPPLY LINE.
INSPECT FOR CORROSION
AND/OR LEAKS
(REFERENCE)

DETAIL A
CABIN HEATER

Figure 1. Cabin Heater Fuel Supply Line and Components (Sheet 1 of 2)

ACCOMPLISHMENT INSTRUCTIONS

MEB95-9

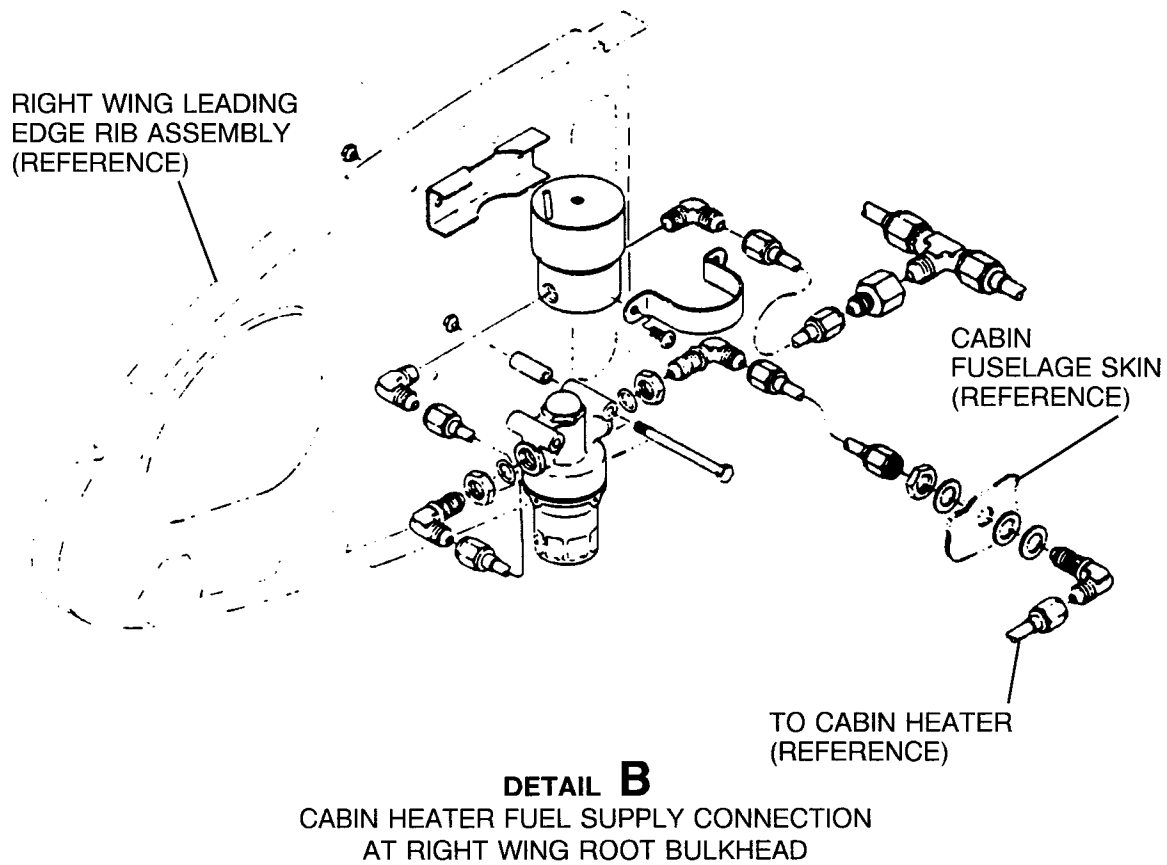
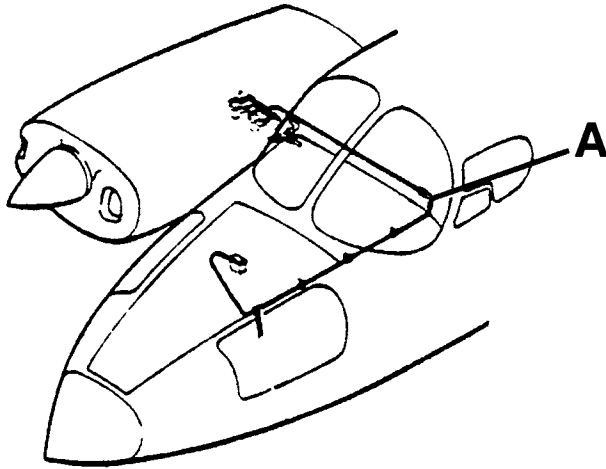

Figure 1. Cabin Heater Fuel Supply Line and Components (Sheet 2)

ACCOMPLISHMENT INSTRUCTIONS

MEB95-9



MODEL 340 SHOWN
(OTHER PRESSURIZED
MODELS SIMILAR)

FUEL LINE TO
FUEL PUMP IN
WING ROOT
(REFERENCE)

CABIN
FUSELAGE SKIN
(REFERENCE)

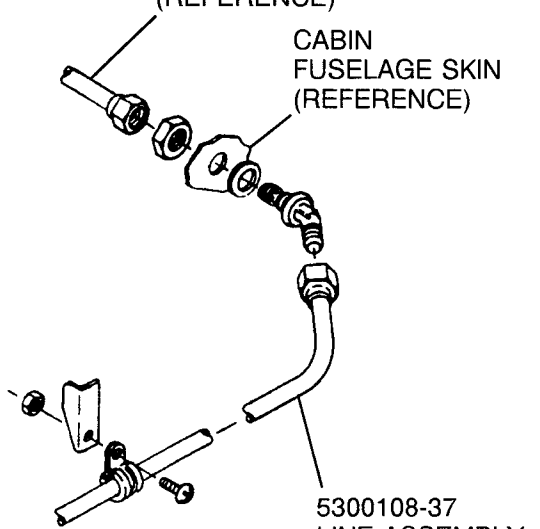

5300108-37
LINE ASSEMBLY
WING ROOT
TO STA 100.00
BULKHEAD.
INSPECT FOR
CORROSION
AND/OR LEAKS
(REFERENCE)

FUEL LINE TO
CABIN HEATER.
INSPECT FOR
CORROSION
AND/OR LEAKS
(REFERENCE)

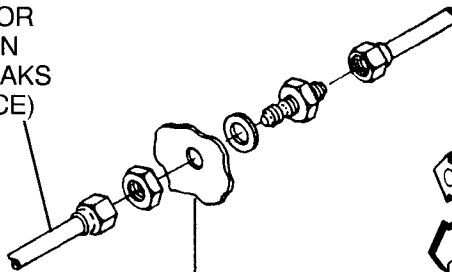

STA 100.00
BULKHEAD
(FORWARD
PRESSURE
BULKHEAD)
(REFERENCE)



DETAIL A
FUEL SUPPLY LINE
PRESSURIZED AIRPLANES
(REFERENCE)

Figure 2. Cabin Heater Fuel Supply Line and Components (Sheet 1)